

IRON-50 230V

GENERAL DUTY DIESEL TRANSFER PUMP

Code: 00190-CF00000

- Vane: Eccentric self-adjusting blades
- Free Flow rate up to 50 l/min
- Delivery head up to 30m
- Self-priming up to 5m
- Internal recycle valve
- Internal 350 micron strainer
- 0.25kW - 230V/1ph/50Hz - IP55
- S1 Continuous duty fan cooled motor
- 3m Cable with plug
- F 1" G Threaded connection
- Anti-rust treatment
- Weight 9 kg

- **OPTIONAL:**
Can be supplied as a drum kit



Flow Curves

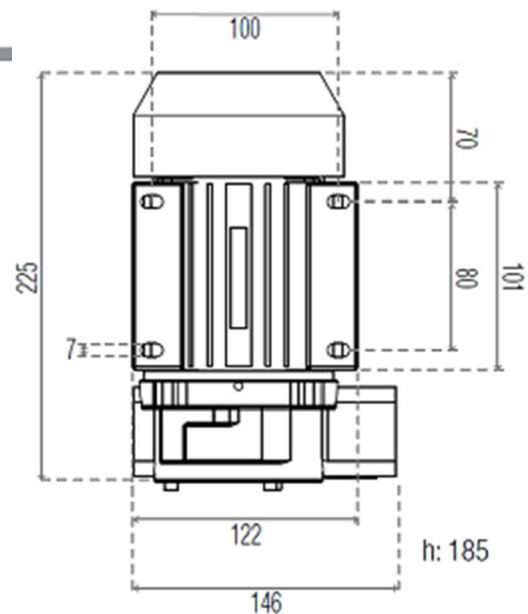
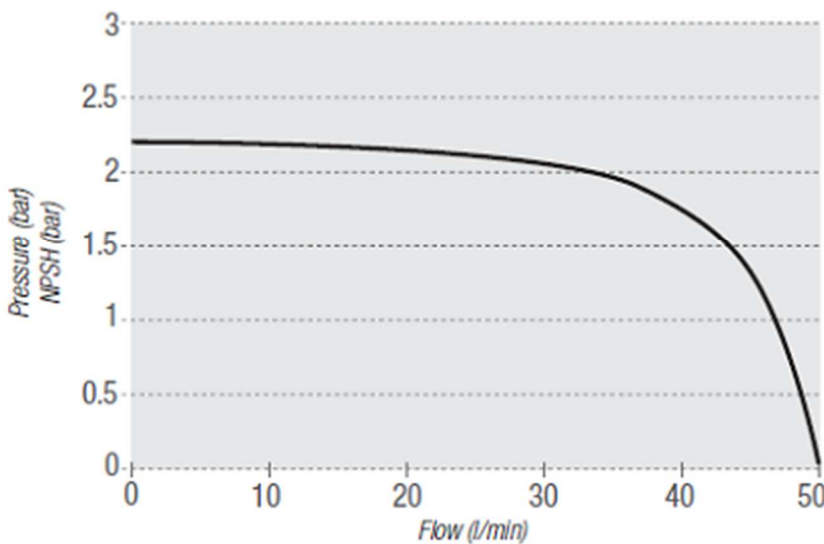

OPTIONAL ACCESSORIES



MGE-110



MG-80A



HOSE



PA-80



PSF-040



FG-70



FG-100